

Bag in Bag™



Vertical Form/Fill/Seal

OVERVIEW

Pillow packages are produced in the upper section of the Bag in Bag machine and then drop down into an overwrap package (pillow or optional flat bottom or gusseted bags) produced on the lower section of the machine.



Upper Section Bag Type



Pillow

Lower Section Bag Types



Pillow



Gusset



Flat Bottom

FEATURES & BENEFITS

- Automatic film tracking
- American Made - Designed and built in Milwaukee, WI
- Stainless steel frame
- Stainless steel NEMA 4X electrical enclosure
- Stainless steel adjustable mounting feet
- Registered film sensors
- Unwind film spindle
- 14" maximum roller diameter
- Allen Bradley MicroLogix PLC
- 10.5" color touch screen
- Bodine gear motors for film pull with Danaher microstepping motors for jaw motion control
- Unique cost effective machine for overwrap bags
- Laminate or poly film sealing capability
- Full compatibility with all types of fillers

The Bag in Bag™ machine provides an innovative solution to fill single serve and multi-serve pillow bags in an overwrap bag for:

- Bakery Products
- Candy and Nuts
- Coffee and Tea
- Fresh Cut Fruit & Vegetables
- Liquid Products
- Pet Products
- Powder Products
- Snack Products

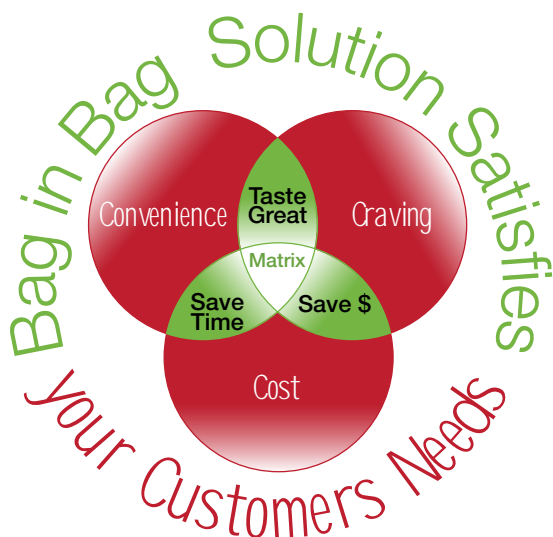

Matrix Packaging Machinery

650 Dekora Woods Blvd.
Saukville, WI 53080

Toll Free: 888-Matrix1
Main Office: 262-268-8300

info@MatrixPM.com

www.MatrixPM.com

powered by Pro Mach

Bag in Bag



Vertical Form/Fill/Seal

TYPICAL SYSTEM HEIGHTS

220" to top of	Combination scale with in-line metal detector
160" to top of	Auger with typical tooling and top plate
165" to top of	Cup filler product hopper (infeed location)



TECHNICAL SPECS

Cycle Speed	Up to 110 BPM (depending on application)	
Electrical	208 - 240 VAC 30 AMP	
Air Pressure	6 - 20 CFM @ 80 PSI (demand varies by application)	
Bag Sizes	Upper (Primary Bag)	Lower (Overwrap Bag)
Width	3" - 9"	3" - 12"
Length	12" maximum	15" maximum



- Hole punch (mechanical or heated)
- Flat bottom and gusset/tucker attachment
- Printer, labeler, valve applicators
- Gas flushing system for M.A.P. applications
- Load shelf for heavier bags (several types)
- UL electrical system

OPTIONS

Front View

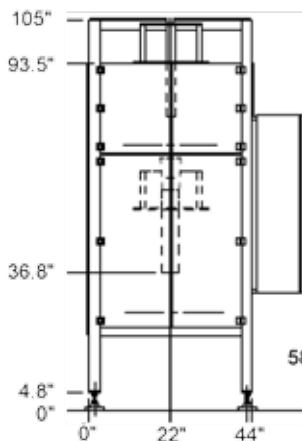

Side View

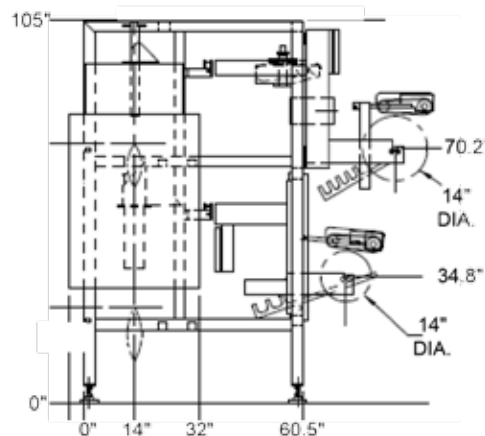

Top View

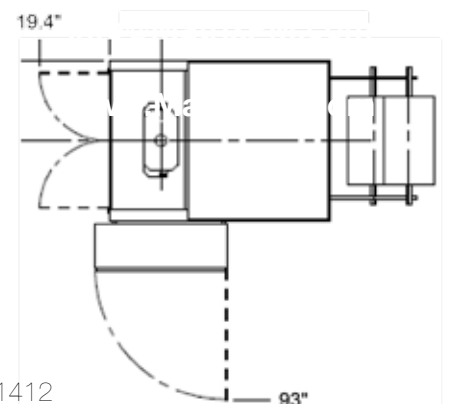

Rev 051412